



Mazda 46G Machine Grey

Repair process

Permahyd® Hi- TEC Basecoat 480
2023

The background of the slide is a dark, high-contrast photograph of a Mazda 46G car, showing the rear quarter panel and trunk area. The car's surface is highly reflective, showing highlights and shadows that emphasize its curves and lines.

Colour assessment &
Product adjustment

Application & Blending

Optional
blending-in procedure

Mazda 46G Machine Grey

- Repair process
- Permahyd® Hi- TEC Basecoat 480
- 2023

Mazda 46G Machine Grey

- Colour assessment & Product adjustment

Mazda 46G Machine Grey

What makes this colour so special?

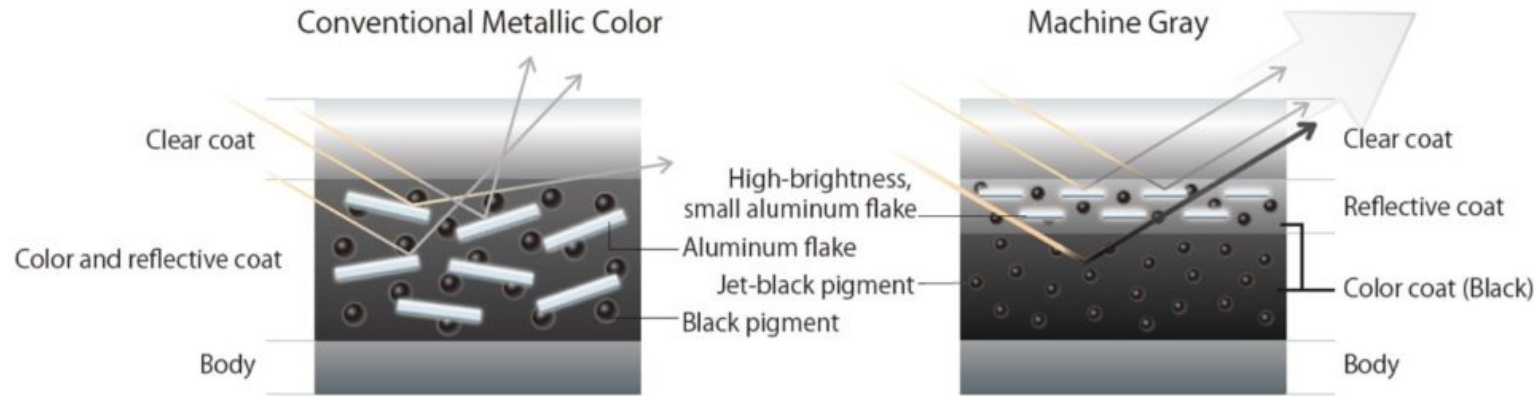

“Machine Grey was developed to express the beauty of a machine’s strength and precision. With strong contrast between light and shadow and a sleek, high-density finish, it gives the impression that the vehicle’s body has been sculpted from a solid steel ingot.”

- For Machine Grey 46G, Mazda engineers developed a special OEM painting process, called „Takuminuri“
- A term which is a combination of both „Takumi“ (skilled craftsman) and „Nuri“ (painting).*

**Source: Text and images Mazda Germany PR

Mazda 46G Machine Grey

What makes this colour so special?



Permasolid® HS clear coat.

Permahyd® Hi-TEC 480 effect coat.

Permahyd® Hi-TEC basecoat 480 ground coat hardened.

Permasolid® HS Surfacer, refer to Phoenix.

- Spies Hecker has developed a special repair process for this colour. This repair process requires the use of special pigments, additives and a special application procedure.
- Other Permasolid® HS clearcoats are also suitable for use on this shade. See the corresponding TDS.
- Available formulae and notes on tints/products required can be found in Phoenix.

Mazda 46G Machine Grey

What makes this colour so special?



- Before starting the repair, make sure that you have the necessary materials available.

Permahyd® Hi-TEC WT197Ultra
Fine Bright Silver

Sales Code: 36201970



Permahyd Hi-TEC
Effect Control 6054.

Sales Code.: 37260540



Colour assessment

Follow the advice in Phoenix.

Colour

ColorDialog

Ancillary Mix

Personal Formula

Tools

News 3

<

MAZDA | 46G | MATRIXGRAU | SIFN+ | 1038219 | EUROPE | 480 - PERMAHYD HI-TEC BASISLACK | 06/04/2023

i

MAZDA | 46G | MATRIXGRAU | SIFN+ | 1038219 | EUROPE | 480 - PERMAHYD HI-TEC BASISLACK | 06/04/2023

Ingredients

Details

Messages (6)

No quick select
v

ADDITION OF 300% 6054 EFFECT CONTROL REQUIRED SPECIAL APPLICATION | APPROXIMATE MATCH ONLY | 3-STAGE COLOR | SP => FORMULA CONTAINS SPECIAL PIGMENT, CHECK AVAILABILITY | USE DEALER LABEL – 480-A | FORMULA CONTAINS NEW TINT - PLEASE CHECK AVAILABILITY

IngrdCd	Description	gram (abs.)	gram (cum.)
WT197	ULTRA FINE BRIGHT SILVER	329.80	329.80
WT188	SUPER DEEP BLACK II	362.05	691.85
WT387	SYSTEM KOMPONENTE B	207.97	899.82
WT385	SYSTEM KOMPONENTE A	51.99	951.81
WT144	GREENISH BLUE	21.24	973.05
WT339	VIOLETT	30.89	1003.94
WT343	BLAU	18.51	1022.45

Colour assessment



Phoenix^(••)



Colour



ColorDialog



Ancillary Mix



Personal Formula



Tools



News

3



Choose a quick select



Group



PH HI-TEC



Product

480



Spray Temperature

< 30°C

> 30°C

Type

SPECIAL COLOR

1. EFFECT (20% WT ADDITIVE)

ACTIVATED

SPOT REPAIR

Style

Hardener

Thinner

6054

Click on Special Color.

TDS: SPECIAL

VOC ✓

9659

Spies Hecker 6054 Effekt Control is now included in the mixing formula

300.00 %



6054



Colour assessment

Colour

ColorDialog

Ancillary Mix

Personal Formula

Tools

News 3

<

MAZDA | 46G | MATRIXGRAU | SIFN+ | 1038219 | EUROPE | 480 - PERMAHYD HI-TEC BASISLACK | 06/04/2023

MAZDA | 46G | MATRIXGRAU | SIFN+ | 1038219 | EUROPE | 480 - PERMAHYD HI-TEC BASISLACK | 06/04/2023

i

Ingredients

Details

Messages (6)

Custom
v

ADDITION OF 300% 6054 EFFECT CONTROL REQUIRED SPECIAL APPLICATION | APPROXIMATE MATCH ONLY | 3-STAGE COLOR | SP => FORMULA CONTAINS SPECIAL PIGMENT, CHECK AVAILABILITY | USE DEALER LABEL – 480-A | FORMULA CONTAINS NEW TINT - PLEASE CHECK AVAILABILITY

IngrdCd	Description	gram (abs.)	gram (cum.)
TARE CAN + MIXING STICK			
WT197	ULTRA FINE BRIGHT SILVER	82.31	82.31
WT188	SUPER DEEP BLACK II	90.35	172.66
WT387	SYSTEM KOMPONENTE B	51.90	224.56
WT385	SYSTEM KOMPONENTE A	12.97	237.53
WT144	GREENISH BLUE	5.30	242.83
WT339	VIOLETT	7.71	250.54
WT343	BLAU	4.62	255.16
STIR			
6054	PERMAHYD HI-TEC 6054 EFFECT CONTROL	750.00	1005.16
STIR, READY FOR USE			

Mazda 46G Machine Grey

What makes this colour so special?

- Before starting application, the material flow must be set on the spray gun:
 1. Tighten the material screw completely.
 2. Now open the material screw by 0.75-1 turn to obtain the required amount of material, use the marking on the fluid control adjustment screw to guide you.
 3. The gun is now set correctly.

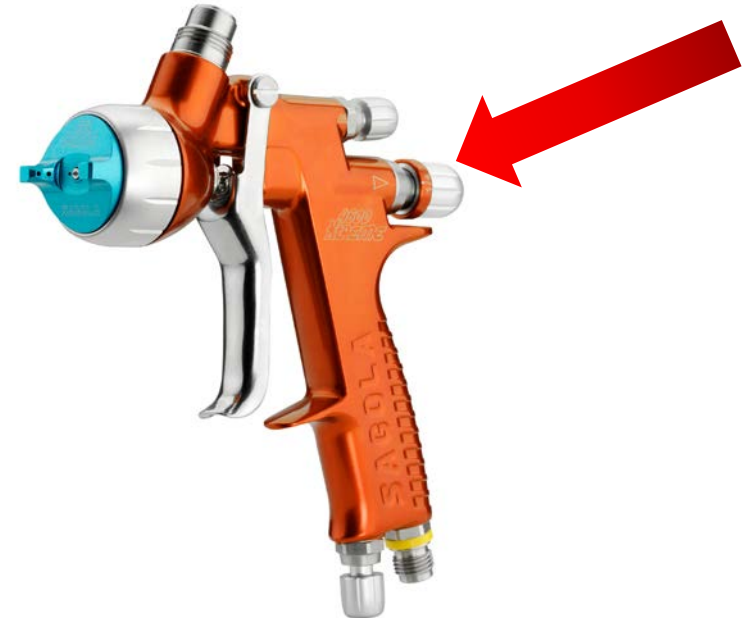

Mazda 46G Machine Grey

Colour matching.

1st

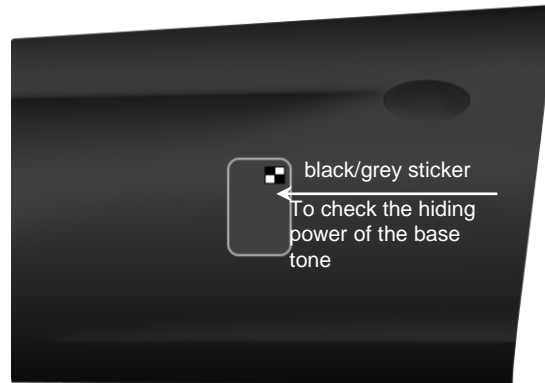

2nd

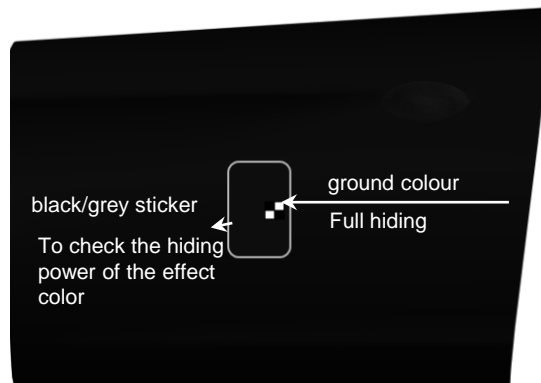

- Please ensure that the Black Permahyd® Hi-TEC Basecoat 480 groundcoat has been hardened with 5% Permahyd® Hardener 3080 prior to the addition of WT Additive 6050/6052 to ensure that a correct final hardness of the paint film is achieved.
- Please use a black/grey sticker to check the hiding power.
- Apply the groundcoat until hiding power is achieved according to the TDS.
- Use another sticker for the effect coat.
- Flash-off and dry according to the TDS.

3. Adjusting the spray gun :

- Spray gun: *Compliant / nozzle: 1.2.
- Spray fan: Fully open.
- Material quantity: 0.75-1 turns
- Inlet pressure: 1.8-2 bar*².
- Distance when spraying: 25-30cm.
- Application: 3-5 uniform spray passes.

4.

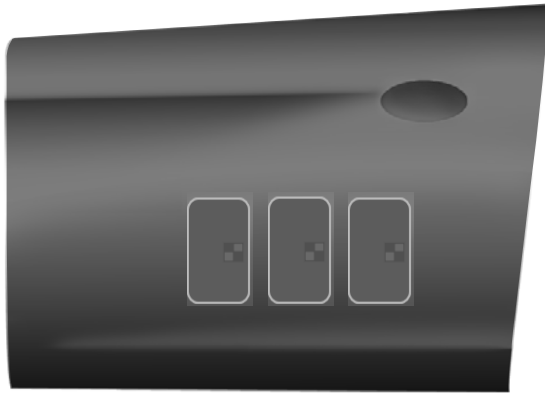

5.

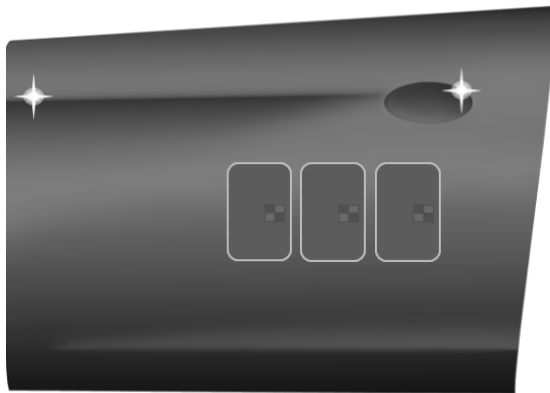

- Paint 3 sample panels with 3, 4 and 5 coats of the effect coat to optimally determine the colour position and effect.
- Effect coats should be applied in a closed, even, thin film to achieve a semi-wet appearance.
- Flash off between coats and wipe with a tack rag
- Check the effect colour with a daylight lamp.
- Apply your chosen Permasolid® HS Clear Coat, recommended in 2 coats.

Mazda 46G Machine Grey

Colour matching.



- Compare the sprayouts made to assess the best match to the vehicle.
- The usage of black & grey sticker for preparing sprayouts is recommended, as is to use them later when painting the car. This will help you to control the transparent application of the effect coat colour.
- During refinishing, the hiding power and effect should be checked. For this purpose, the sprayout, which was previously determined as the best match, should be used.

Mazda 46G Machine Grey

Colour matching.



- Due to a larger number of available colour variations and the very different appearance on the individual Mazda models, please select the availability via "all regions" in Phoenix.
- This special application method is required to achieve the required effect.
- Mix the required formulae via Phoenix.
- **There are large differences in colour tone and effect from model series to model series, within a model series and sometimes on one and the same vehicle (component to component).**
- **For this reason, a large-area paint job should be taken into account for colour matching.**

Mazda 46G Machine Grey

- Application & Blending

Mazda 46G Machine Grey

Blending-in procedure.



- Use the colour level recommended in Phoenix to select the correct Permasolid® 2K Surfacer. This is usually CL3.
- Sand the surfacer with P500-P600 and the paint-in area with P1500-P2000.
- Clean thoroughly
- Prepare hardened Blend-in Additive & groundcoat colour according to Phoenix.

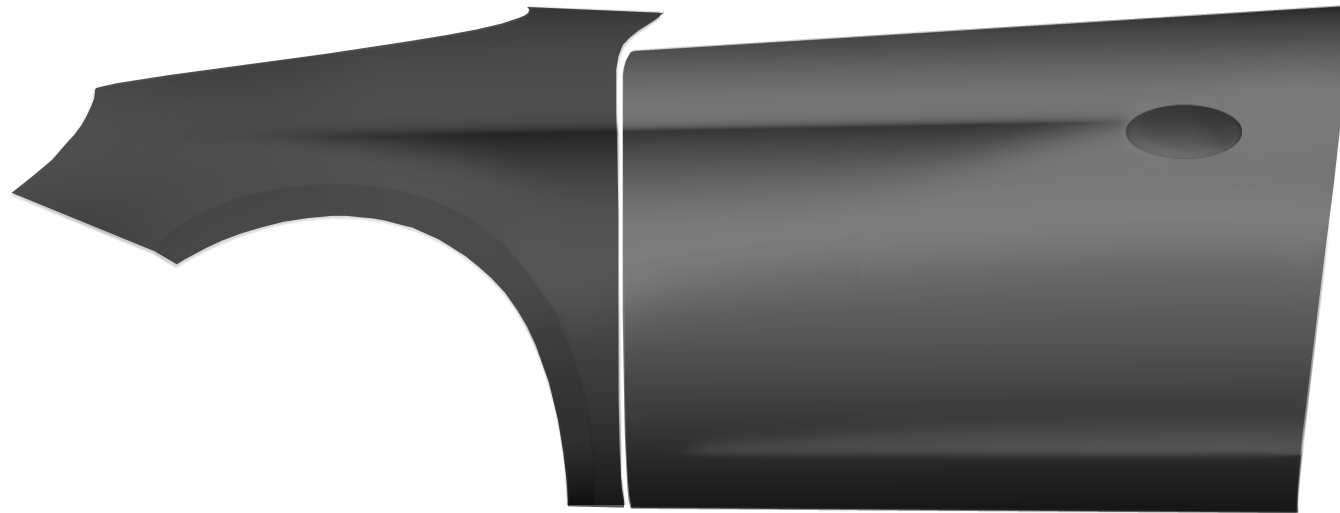

Mazda 46G Machine Grey

Blending-in procedure.



- Apply Permahyd® Hi-TEC Blend-in Additive 1050/1052 hardened with 5% Permahyd® Hi-TEC Hardener 3080 to the adjacent panel. Do not apply to edge of the panel.
- Depending on the local climatic conditions, a longer product setting of Permahyd® Hi-TEC Blend-in Additive 1050/1051 with 5% Permahyd® Hardener 3080 may result in easier wetting, lower film thickness and better control.

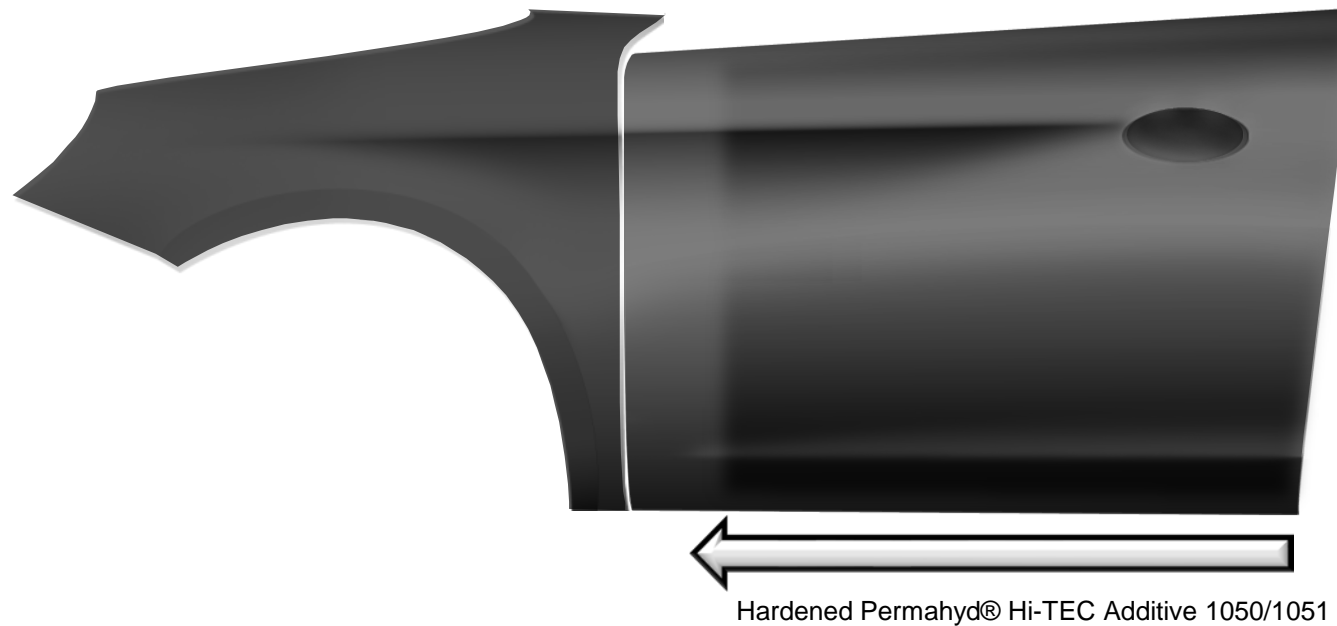

Mazda 46G Machine Grey

Blending-in procedure.



- Spray 1.5 coats of ground colour to repair panel and blend into the still wet Blend.-In Additive.
- Use reduced fluid flow with groundcoat colour to prevent coarse overspray formation in blending area.
- Work towards repair area if possible to reduce droplet formation and create a soft blend.
- Force dry for 10mins@60C. Allow to cool.

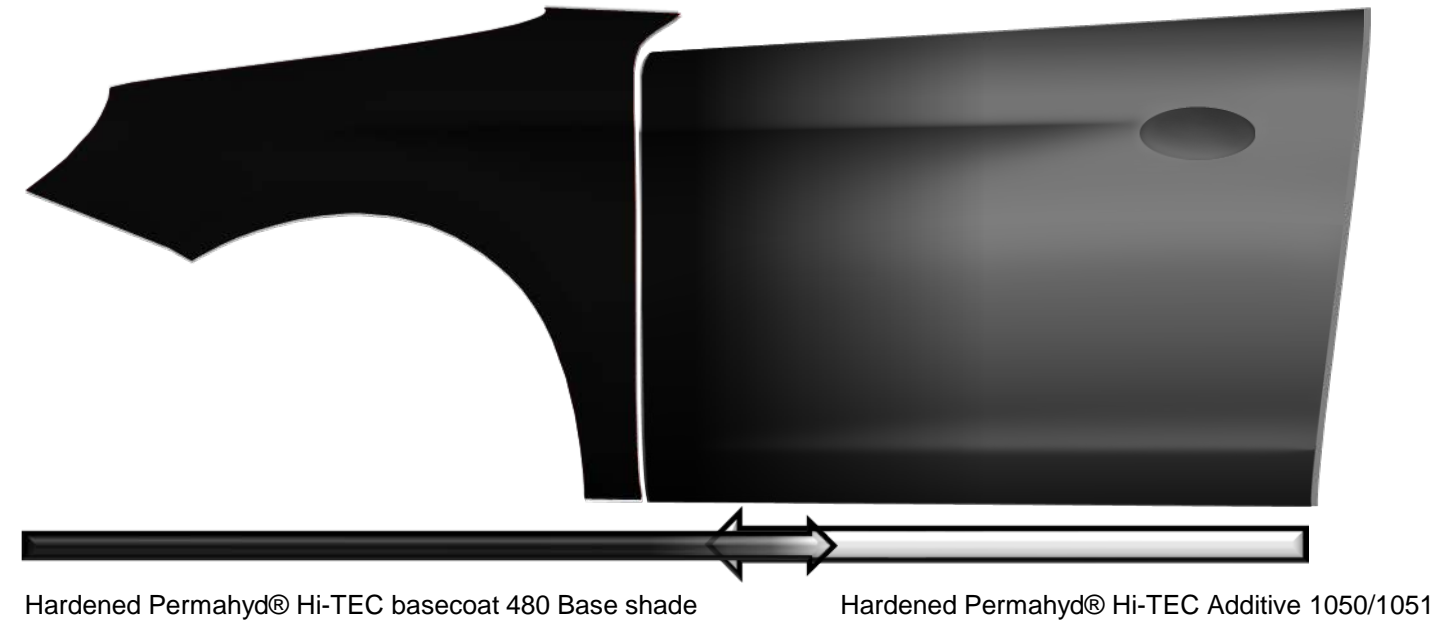

Mazda 46G Machine Grey

Blending-in procedure.



- Mix Permahyd® Hi-TEC effect shade according to Phoenix.
- Please take into account the instructions regarding application in advance.

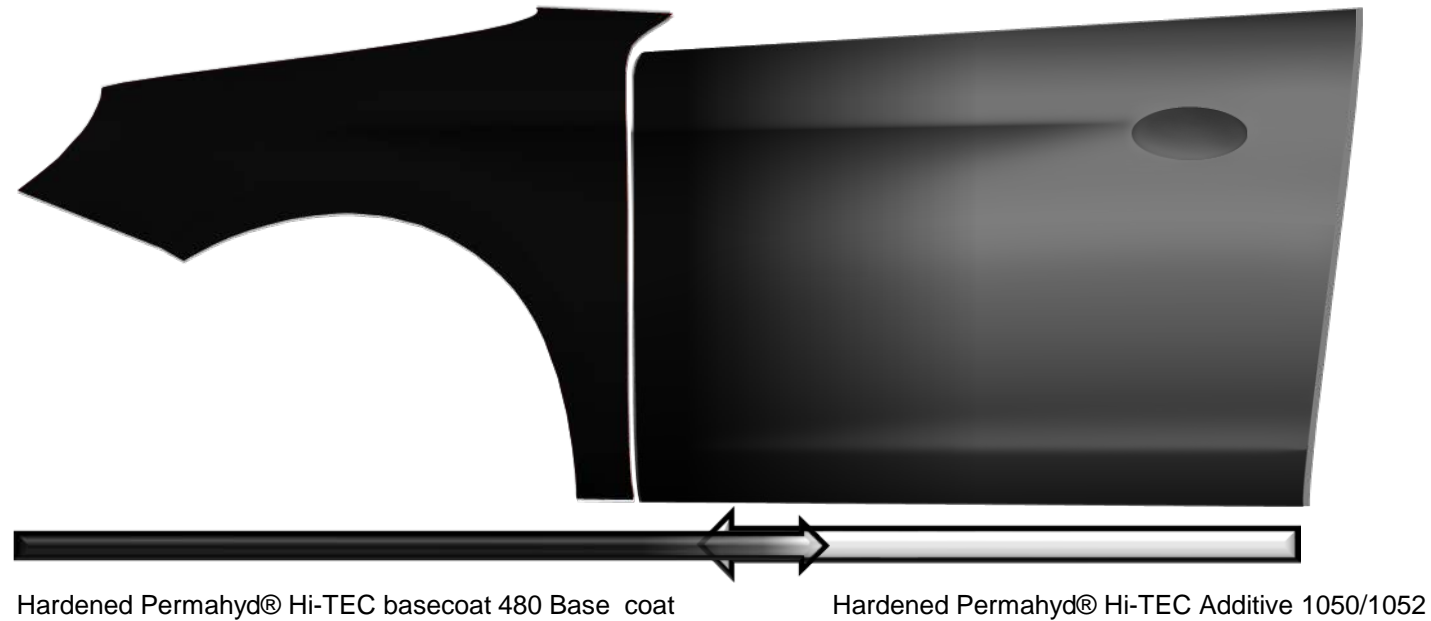

Mazda 46G Machine Grey

Blending-in procedure.



- The effect coat should be applied in 3-5 single even closed coats to create a homogeneous semi-wet surface.
- Apply to the widest area first, application distance 25-30cm.
- Flash off between coats.
- Increase the spraying distance in the last pass to approx. 35 cm to correct possible cloud formation.

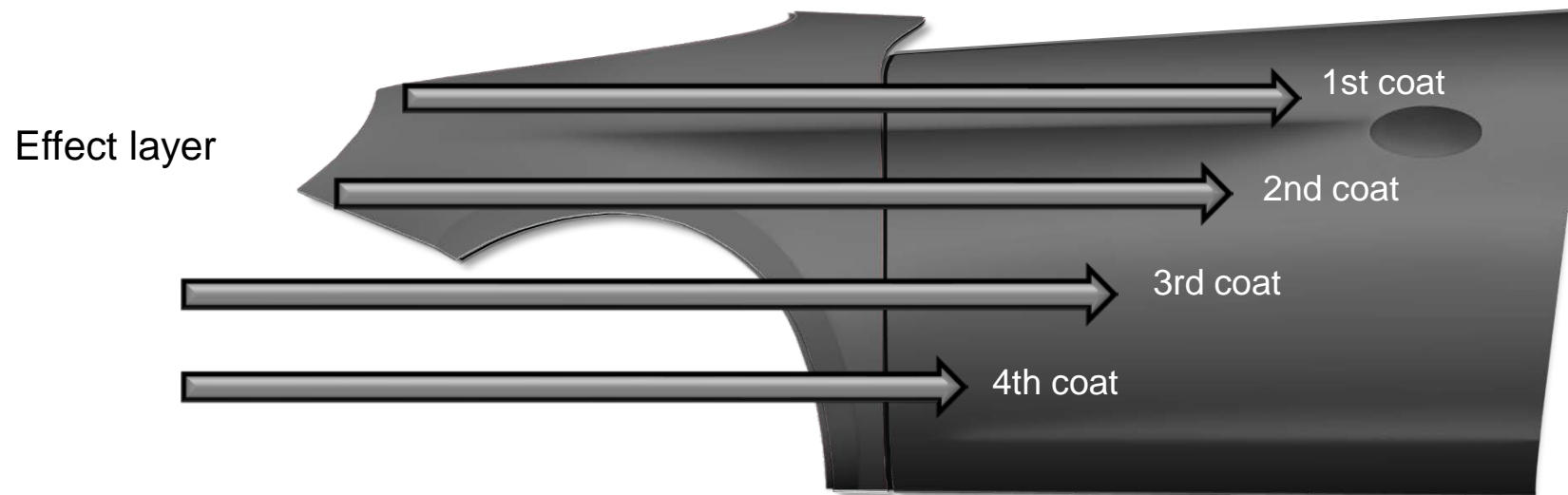

Mazda 46G Machine Grey

Blending-in procedure.



- Before applying the clear coat, check the application of the effect layer with a daylight lamp. Make sure that the base colour is completely covered in the transition area.

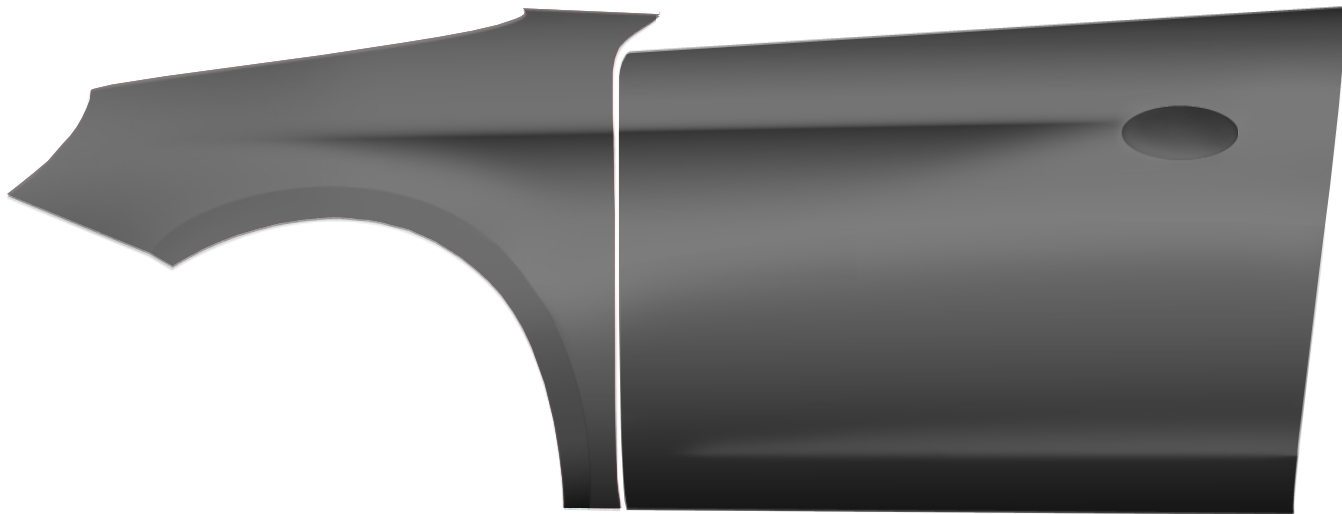

Mazda 46G Machine Grey

Blending-in procedure.



- Apply Permasolid® HS Clear Coat to the entire repair area.
- Dry according to the respective TDS.

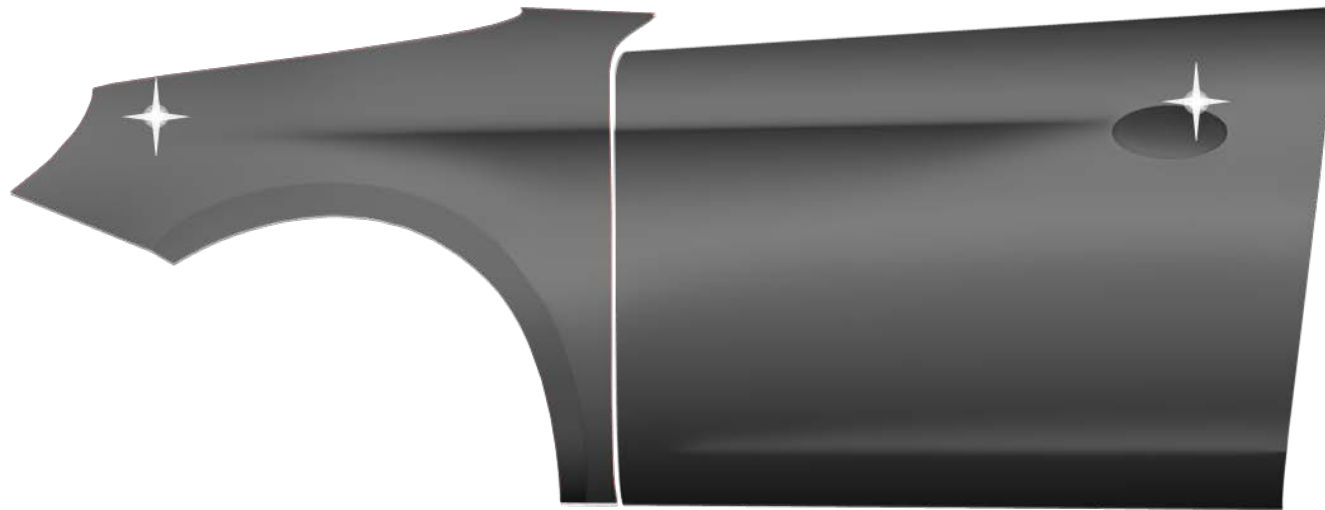

Mazda 46G Machine Grey

- Optional blending-in procedure

Mazda 46G Machine Grey

Optional blending-in procedure.



- Use the colour level recommended in Phoenix to select the correct Permasolid® 2K Surfacer. This is usually CL3.
- Sand the filler with P500-P600 and the blend-in area with P1500-P2000.
- Clean thoroughly.

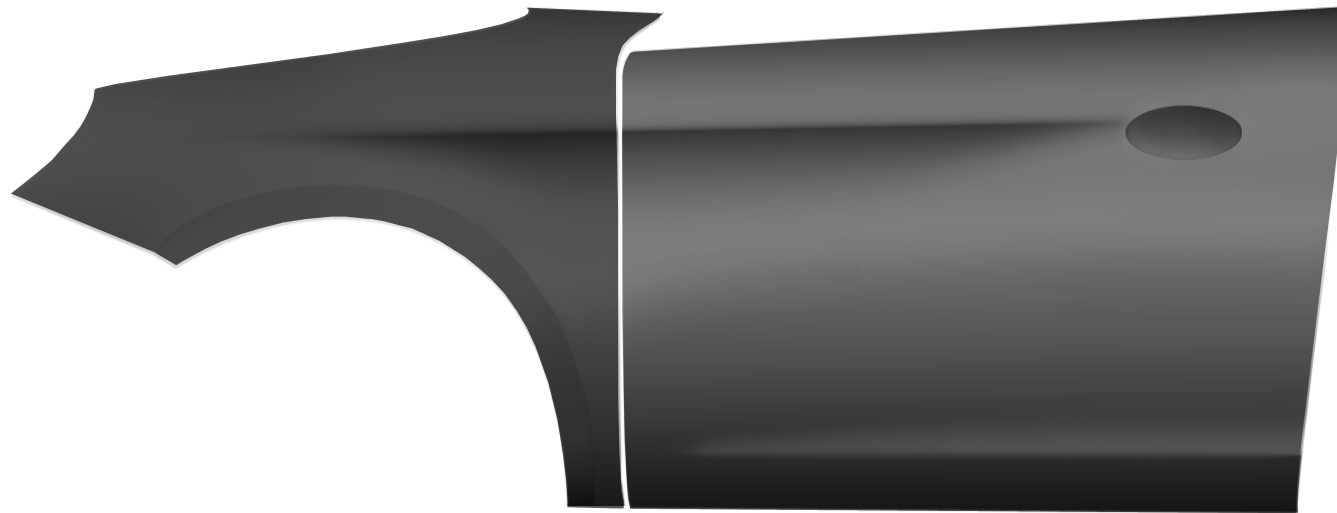

Mazda 46G Machine Grey

Optional blending-in procedure.



- Mask the blend-in panel
- Mix Permahyd® Hi-TEC Basecoat 480 groundcoat colour according to Phoenix. Make sure that 5% Permahyd® Hardener 3080 is added to the groundcoat before mixing with 6050/6052.
- First apply a "soft" basecoat to the adjacent component/repair part to be painted, then apply a covering coat to the repair part. Avoid hard edges of the base colour shade as well as excessive spraying.
- Flash-off times according to TDS.

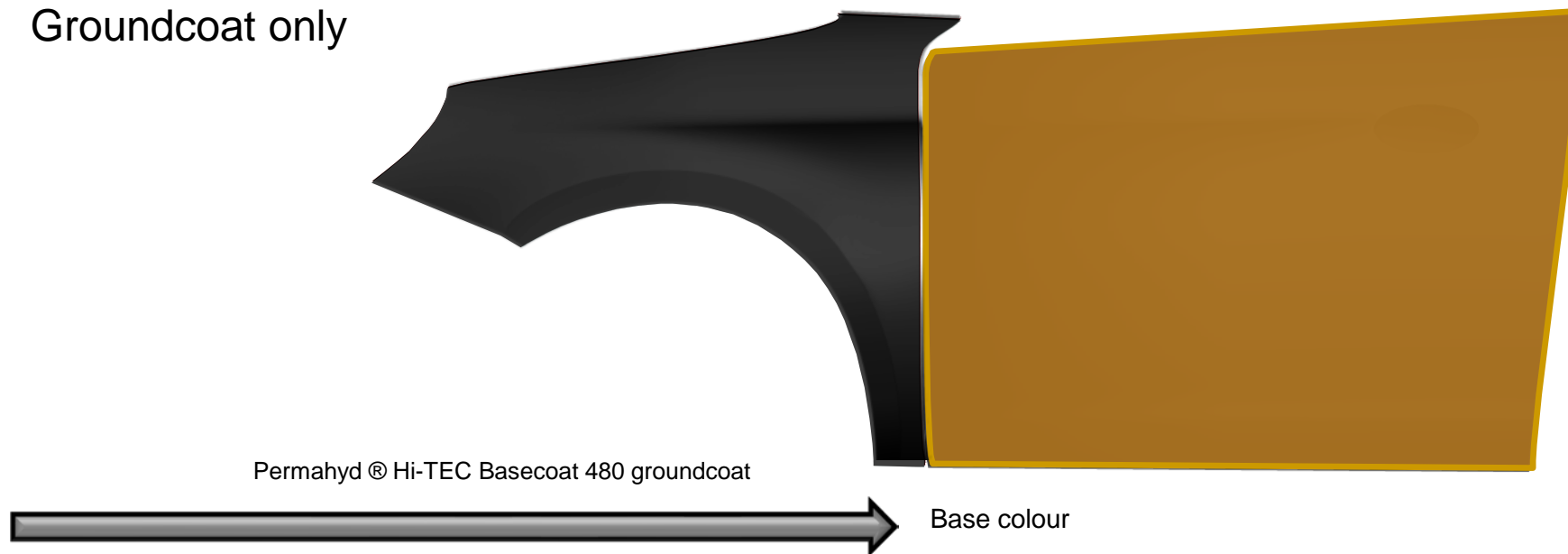

Mazda 46G Machine Grey

Optional blending-in procedure.



- The effect coat should be applied in 1 - 2 single even closed coats to create a homogeneous semi-wet surface.
- Flash off between coats.

Effect coat only

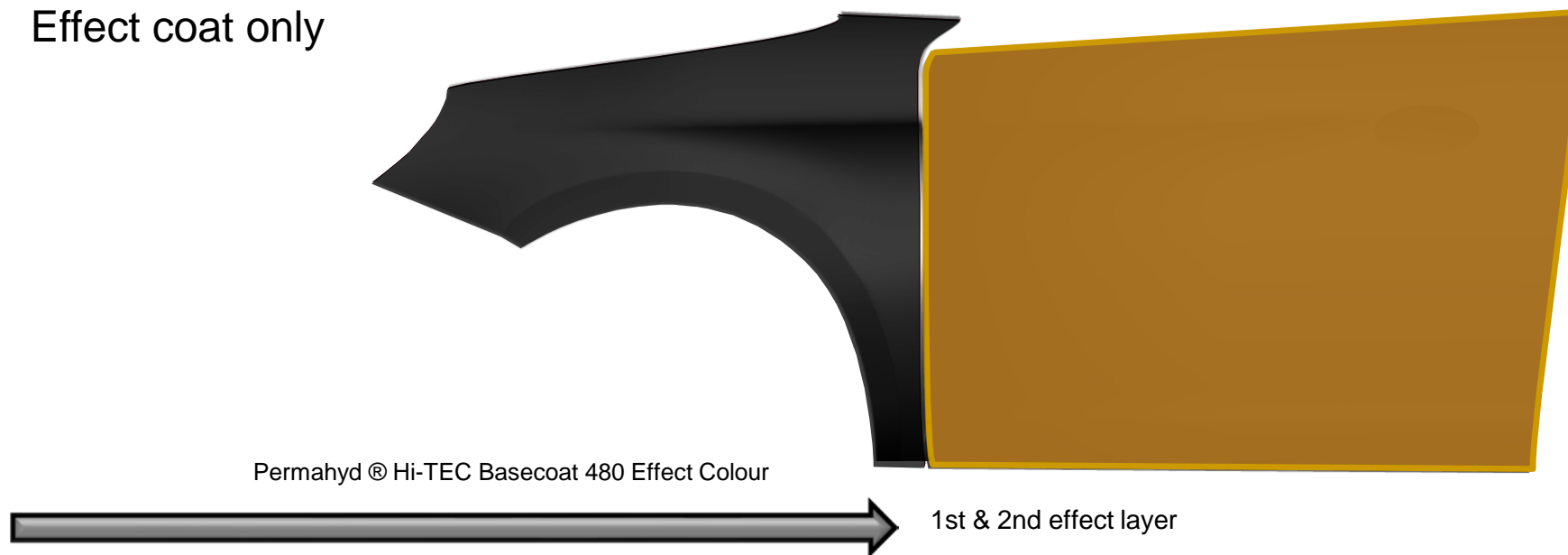

Permahyd ® Hi-TEC Basecoat 480 Effect Colour

1st & 2nd effect layer

Mazda 46G Machine Grey

Optional blending-in procedure.



- Carefully remove the masking paper after both coats have dried.
- Apply the effect colour evenly to the part to be blended and over the repair part in 2 single coats.
- Allow to flash off between the individual coats.
- Start with the widest spray pass first, spraying distance 25-30cm.
- Increase the spraying distance in the last coat to approx. 35 cm to correct possible cloud formation.

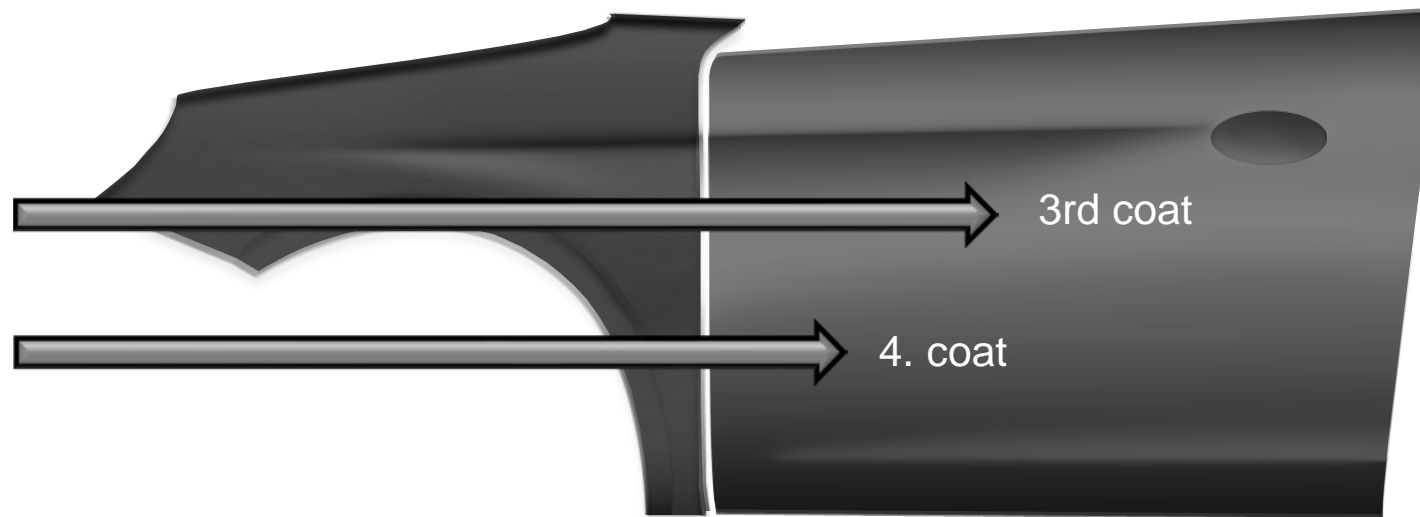

Mazda 46G Machine Grey

Optional blending-in procedure.



- Apply Permasolid® HS Clear Coat to the entire repair area.
- Dry according to the appropriate TDS.

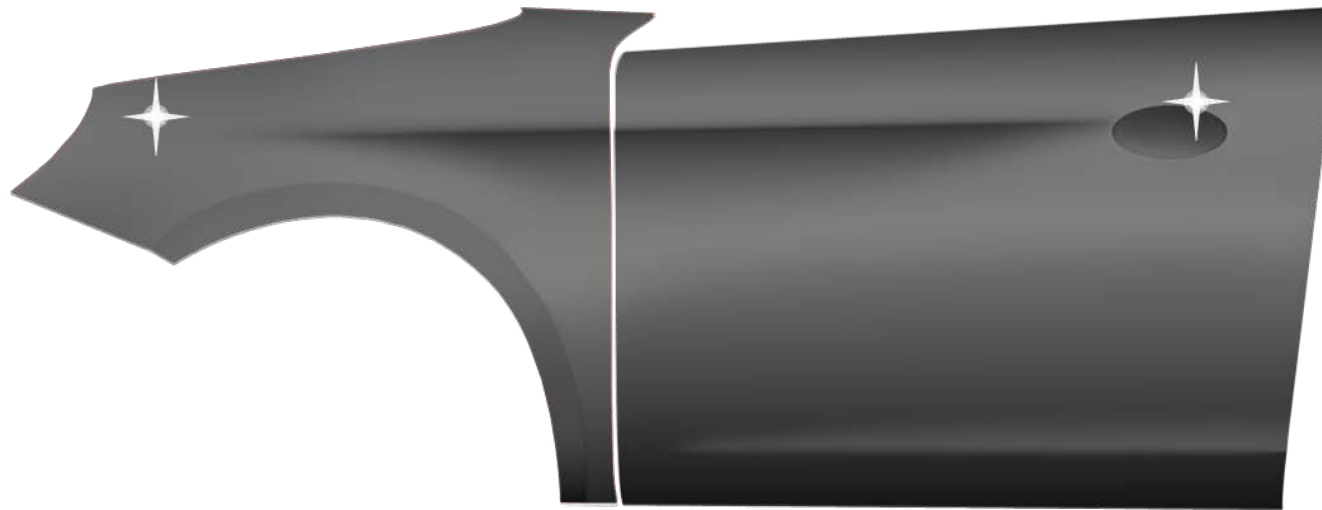

Application of the groundcoat:

Apply the groundcoat to create a soft transition into the adjacent part, keep as small as possible.

Application of the effect layer :

Adjust the spraygun correctly prior to application.

It may be beneficial to use an anti-static gun before and between effect coats.

Adhere to the spray distance and recommended procedure.

Paint with tight overlaps to produce an even result.

Dry the individual effect layers between coats e.g. with a hand blower.

Use a tack rag between coats.

Increase the distance to 35cm during the last spraying pass to correct cloud formation, if necessary.

Mazda 46G Machine Grey

Tips & Tricks.



The effect layer should have this structure:





Thank You.